

Turbidity and Solids Content Sensor *TurbiMax P CUS 62*

Turbidity and Solids Content Sensor for High Concentrations in Hazardous Areas Using the Light Absorption Method



The TurbiMax P CUS 62 sensor is used for optical solid matter content measurement in turbid water for up to 50g solid matter/l for applications in hazardous areas.

Applications

- Solid matter content measurement of suspended matter in sewage treatment plants:
Primary sludge, digested sludge, thickened sludge,
Inflow to centrifuge / press
- Industrial quality control

Features and benefits

- Reliable concentration measurement using optical measuring process
- Four-beam pulsed light method for compensation of sensor soiling and ageing of optical components
- Stainless steel sensor body
- No mechanically moving parts
- Measured value preprocessing in sensor resulting in low signal transmission sensitivity



Measuring system

The complete measuring system for hazardous areas comprises:

- Turbidity measurement transmitter CUM 740
- Turbidity sensor TurbiMax P CUS 62
- Zener barrier 7900 ZB
- Assembly for installation or immersion

Example of a measuring system

CUM 740 with CUS 62-G1

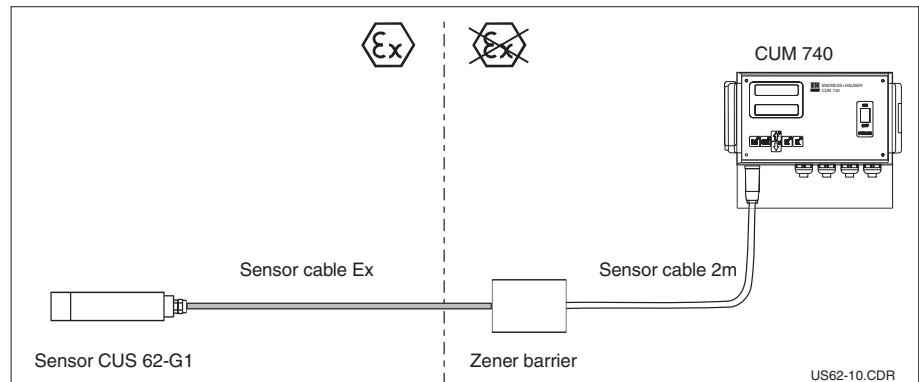

Measuring system CUM 740 with CUS 62-G2

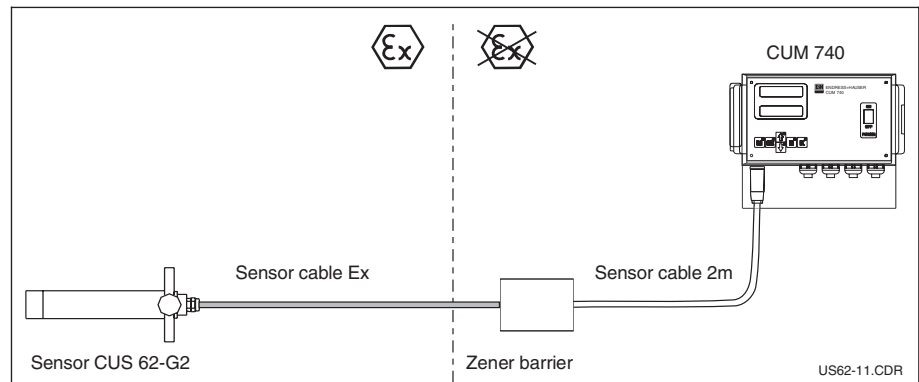

Measuring principle

Turbidity measurement

By turbidity we mean the scattered component of a light beam which is diverted away from its original course by optically denser particles in the medium e.g. solid matter particles.

Four-beam pulsed light method

This method is based on two light sources and two photoreceivers. Long-life LEDs (at least 20,000 operating hours) are used as monochromatic light sources.

To eliminate interference from extraneous light sources, the LEDs are pulsed at a rate of several kHz.

Two measuring signals are detected at the two photoreceivers with every light pulse. The four measuring signals are compared with each other logarithmically and converted to a ratio. This compensates for detector soiling and the ageing of optical modules.

Light absorption method

This measuring method is based on the Lambert-Beer law. Turbidity is measured by light attenuation.

The LEDs on the sensor send a directed light beam to the photoreceivers. The intensity of the beam is attenuated by solid matter particles in the medium. The photoreceivers measure the absorption signal and convert it into a frequency signal. The frequency signals are assigned to corresponding turbidity units and solid matter concentrations, and appear in the display.

left:
Principle of measured light radiation
S = Transmitter
E = Receiver

right:
Principle of measured light attenuation analogue to Lambert-Beer's law

- I_0 = Intensity of transmitted light
- I_A = Intensity of absorbed light
- I_T = Intensity of light transmitted
- I_S = Intensity of scattered light
- E = Extinction coefficient
- C = Concentration
- D = Optical path length

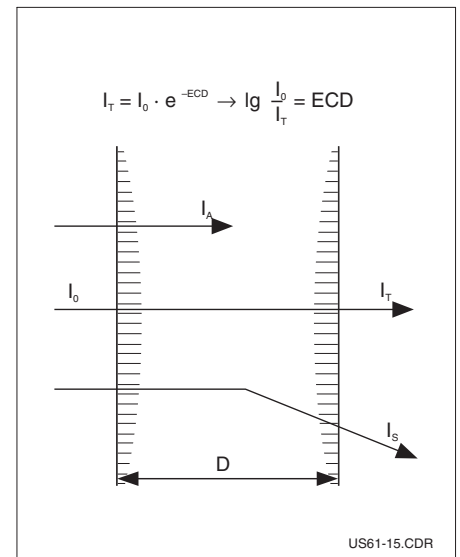
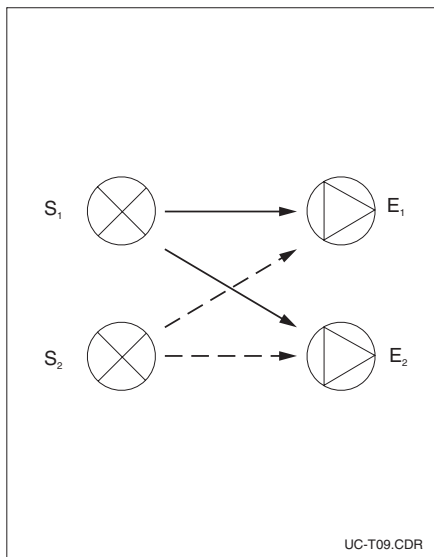

Calibration

Each sensor is subjected to a careful calibration at the factory. One customer-defined calibration can also be saved.

For the calibration of solids content measurement, such as sludge, refer to the concentration determined by a reference method (dry substance).

Dimensions

Dimensions CUS 62

left:
CUS 62 Immersion type

right:
CUS 62 Installation type

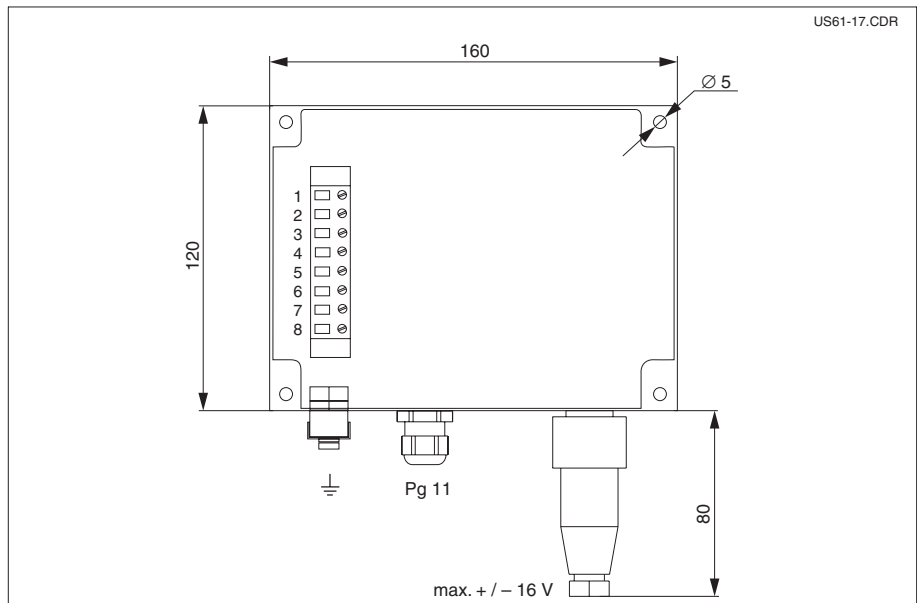
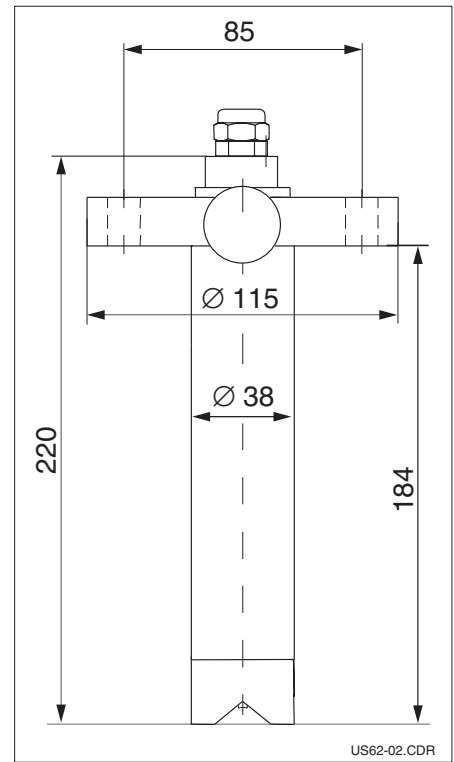
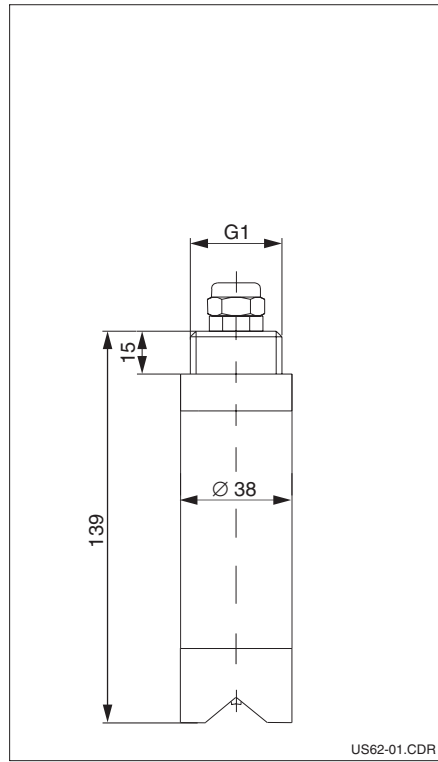

Dimensions
Zener barrier
7900 ZB

1	2	3	4	5	6	7	8
bl	pk	wt	bn	gn	ye	gn	bk
+dig	0Vdig	+at	0V at	Status	AV	screen	PAL

Installation

Installation example of
CUS 62
Immersion type
Tank installation

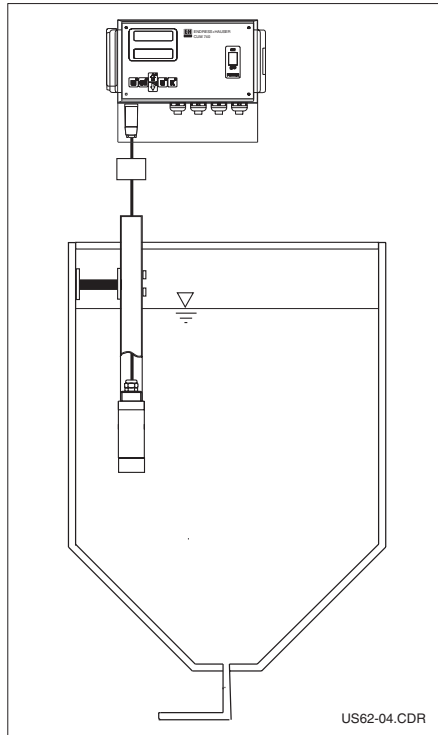

Installation example of
CUS 62
Installation type
Tube installation with ball
valve built-in assembly
(accessories)

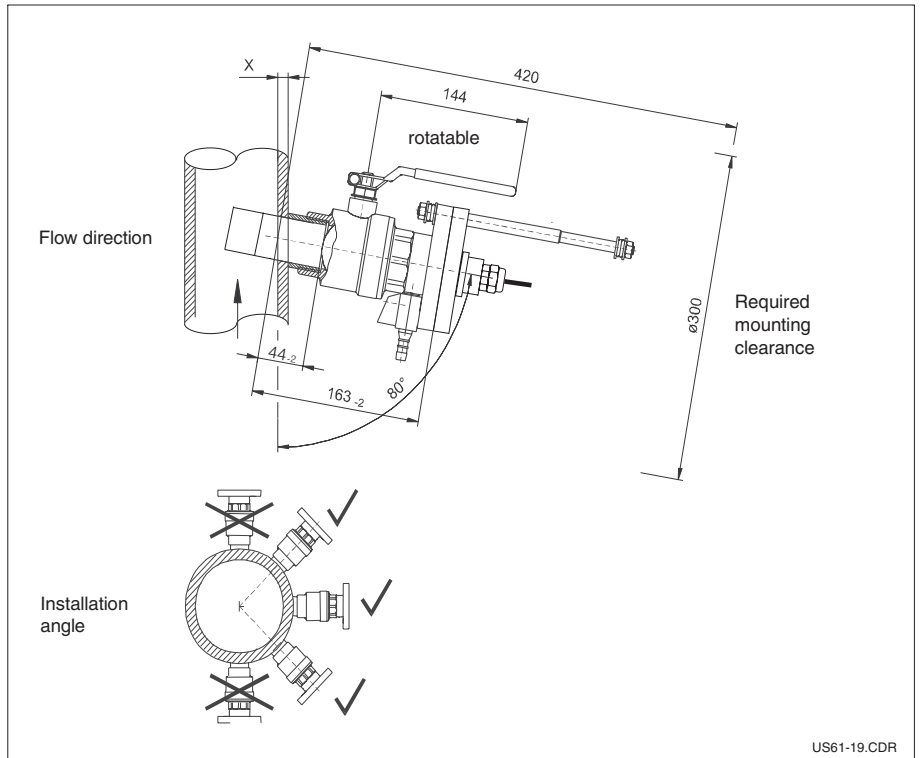

Note:

- We recommend the use of an immersion tube for the CUS 62 immersion type.
- Installing the sensor in pipelines or close to a wall can lead to back-scattering and therefore to signal increase.

Accessories

- ❑ Ball valve built-in assembly for sensor extension under process conditions, DN 40 with safety lock
Material: stainless steel SS 316 Ti,
O-rings made of Viton®
Order No.: 51503588
- ❑ Sensor fixing bracket for basin mounting
Material: stainless steel SS 316 Ti,
Order No.: 51503626
- ❑ Immersion tube 1m
Material: stainless steel SS 316 Ti
Order No. 51506000
- ❑ Immersion tube 2m
Material: stainless steel SS 316 Ti
Order No. 51505994

Technical data

General data	Manufacturer	Endress+Hauser
	Product designation	TurbiMax P CUS 62
Mechanical data	Dimensions (L x Ø) Immersion type Installation type	139 x 38 Ø mm 220 x 38 Ø mm
	Weight Immersion type Installation type	approx. 1kg approx. 3kg
Material	Sensor body	Stainless steel SS 316 Ti
	Sight glass	Epoxy resin
	O-rings	Viton®
Turbidity measurement	Measuring principle	Light absorption method
	Optical components	Light source: 2 LEDs, Detector: 2 photodiodes
	Measuring light	Infrared light at 880nm (absorption maximum)
	Measuring range	0 ... 50g solid matter/l, dependent on sludge type
	Accuracy	< 1% of measuring range end value
	Reference	Using four-beam pulsed light method
	Factory calibration	SiO ₂
	Cable lengths	13m, 25m, 25 ... 100m
	Connecting cable length of Zener barrier to transmitter	2m
Operating conditions	Operating temperature	0 ... +50°C
	Operating pressure	max. 6 bar
	Ingress protection	IP 68
	Explosion protection	EEx ib IIC T4
Supplementary documentation	Technical Information CUM 740	Order No.: 51504296

Subject to modifications.

Product structure

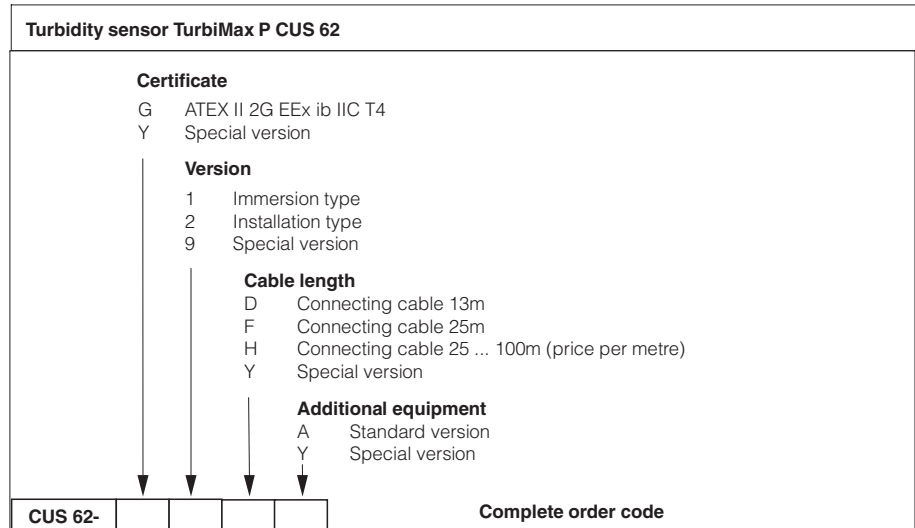

Endress+Hauser
GmbH+Co.
Instruments International
P.O. Box 2222
D-79574 Weil am Rhein
Germany

Tel. (0 76 21) 9 75-02
Fax (0 76 21) 9 75-345
<http://www.endress.com>
info@ii.endress.com

Endress+Hauser
The Power of Know How

