

Sensors for Chlorine Dioxide *CCS 240 und CCS 241*

Membrane-covered, amperometric sensors for installation in flow assembly CCA 250



The chlorine dioxide sensor CCS 240 has been specifically designed for applications with a measuring range between 0.05 ... 20 mg ClO₂/l. The CCS 241 sensor is intended primarily for use in drinking water treatment or chlorine dioxide trace detection with a measuring range between 0.01 ... 5 mg ClO₂/l.

The dissolved chlorine dioxide concentration after production in the sodium chlorite/hydrochloric acid (NaClO₂/HCl) or sodium chlorite/chlorine gas (NaClO₂/Cl₂) process can be measured.

Areas of applications

- Drinking water conditioning
- Swimming water conditioning
- Service water applications

Benefits at a glance

- Minimum flow requirement for installation in CCA 250 flow assembly: 30 l/h
- Measurement is virtually independent of flow rate above 30 l/h
- No zero point calibration is required, i.e. the complicated installation of an active carbon filter, as, for example, in open chlorine sensors, is unnecessary
- Measured values are not affected by conductivity fluctuation
- The CCS 240 sensor is ready for measurement after approx. 10 to 30 minutes of polarisation while the CCS 241 requires 45 to 90 minutes
- Simple membrane change due to ready-made membrane head
- Recalibration cycles are approx. 1 to 4 months under constant operating conditions
- Outlet back-pressure up to 1 bar

Drinking water, industrial service water and pool water must be disinfected with suitable oxidising agents such as chlorine dioxide.

Depending on the operating conditions, it may be necessary to dose with oxidising agents instantly whenever required. Too low a concentration may compromise the disinfection success. Too high a concentration may result in corrosion, unpleasant taste and skin irritation.



Measuring system

The membrane-covered amperometric chlorine dioxide sensors CCS 240 and CCS 241 are intended for installation in the CCA 250 assembly. The sensors can be connected to the chlorine dioxide measuring transmitter CCM 121 / 151. The field housing version CCM 151 can be optionally be installed in the compact measuring station CCE 1 or CCE 3.

Operating principle

The membrane-covered sensor consists of a cathode serving as the working electrode and an anode acting as the counter-electrode. These electrodes are immersed in an electrolyte. The electrodes and electrolyte are separated from the medium to be measured by a membrane. This membrane prevents the loss of electrolyte and penetration of contaminants which can cause

When the sensor is immersed in measuring water containing chlorine dioxide, the chlorine dioxide diffuses through the membrane. The chlorine dioxide molecules impinging on the cathode (electron surplus) are reduced to chloride ions. At the anode, silver is oxidized to silver chloride. The resulting maximum diffusion current is a direct measure of the concentration of dissolved chlorine dioxide.

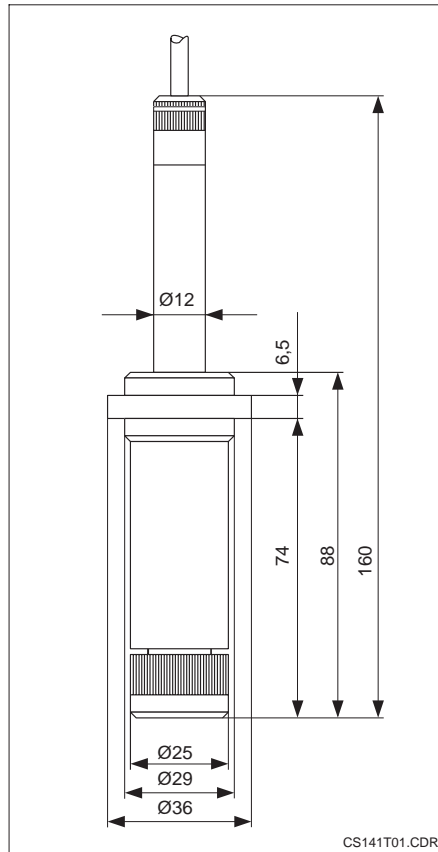

Dimensions of
CCS 240/241

“poisoning”. A fixed polarisation voltage is applied between the anode and the cathode.

Technical data

General data

Manufacturer	Endress+Hauser
Product designation	Chlorine dioxide sensor CCS 240/241

Material

Shaft material	PVC
Membrane material	PTFE
Membrane cap	PBT (GF 30), PVDF

Electrical connection

Cable connection	3 m four-core, double screened cable, low noise
------------------	---

Conductivity measurement

Measuring system	passively operated sensor with gold cathode and silver/silver chloride anode
Temperature sensor	NTC, 10 k Ω bei 25 °C
Measuring range CCS 240	0.05 ... 20 mg ClO ₂ /l
Measuring range CCS 241	0.01 ... 5 mg ClO ₂ /l
Polarisation time of CCS 240	first polarisation 30 min repolarisation 10 min
Polarisation time of CCS 241	first polarisation 90 min repolarisation 45 min
Response time	90 % of final value: < 2 min 99 % of final value: < 5 min

Subject to modifications.

Accessories

- CCY 14-WP
2 ready to use replacement cartridges for CCS 240/241 cells
- CCY 24-F
50 ml ready to use filling electrolyte for CCS 240/241

Order No.

50005255

50064294

Supplementary documentation

Technical information

- Flow assembly for free chlorine and chlorine dioxide CCA 250 50052556
- Compact chlorine measuring station CCE 1/CCE 3 50050696
- Mycom CCM 121/151 50058720
- Microprocessor photometer for chlorine and chlorine dioxide detection CCM 181 50068528

Product structure

Chlorine dioxide sensor CCS 240

Version

N With NTC temperature sensor



CCS 240-

complete order code

Chlorine dioxide trace sensor CCS 241

Version

N With NTC temperature sensor



CCS 241-

complete order code

Endress+Hauser GmbH+Co.
- Instruments International -

P.O. Box 2222
D-79574 Weil am Rhein
Tel. (07621) 975 - 02
Fax (07621) 975345

Endress + Hauser
Nothing beats know-how

